



VIKING JOHNSON

World leaders in pipe joints and repair products

The Viking Johnson range of MegaFit products - *universal pipe couplings* - MEGAFIT



MegaFit

Universal couplings

The Viking Johnson MegaFit range of universal pipe couplings represents the very best in wide tolerance pipe coupling technology. MegaFit products are designed to connect plain ended pipes of the same nominal bore, with same or different outside diameters, thereby reducing stocks, as one coupling is able to connect steel, ductile iron, PVCu, cast iron and asbestos cement pipes.

Application

MegaFit products are designed for use in repair situations where the exact outside diameter of the pipes are unknown.



Universal

The concept of MegaFit is to optimise stockholding and simplify installation. To achieve this, MegaFit offers an OD tolerance range of up to 34mm, which has the effect of reducing stockholding down to one size per nominal diameter. This benefit is also appreciated by the installer, as only one product needs to be selected to effect a repair.

Full range

The MegaFit product range includes couplings and flange adaptors, which are available from DN50 (2") to DN300 (12").

Guaranteed sealing

The unique patented 'slide easy' gasket provides maximum sealing pressure, even on scored, pitted and corroded pipe surfaces through its distinctive circumferential ribs.

The MegaFit range seal is based on the well proven and patented closed chamber principle. The end ring is designed in such a way that the gasket is completely enclosed. This reduces the contact area of the gasket with the backfill material, virtually eliminating the possibility of harmful substances coming into contact with the gasket.

Working pressure

The MegaFit range is suitable for water and gas applications. Following extensive tests, carried out to DIN 3387, the products can be guaranteed for a working pressure of 16 bar for water applications (test pressure 24 bar) and 4 bar for gas (test pressure 6 bar).

Angular deflection

MegaFit couplings accommodate angular deflection between pipes of up to 8°, allowing for ease of installation and for pipeline movement such as ground settlement.

This angular deflection can be utilised to lay pipelines to long radius curves, without the need for special fittings. (Flange adaptors have half the angular deflection of couplings.)

User friendly

The MegaFit range is supplied with captive bolts, meaning that the nuts need only to be tightened at one end, saving time and simplifying installation. Due to its ergonomic shape, MegaFit weighs up to 8kg less than comparable products on the market, making it much easier to handle. MegaFit also includes an extended centre sleeve which aids installation.



Product quality

MegaFit products are designed and manufactured under quality management systems to BS EN ISO 9001 and have been tested by Viking Johnson's comprehensive in-house research facilities to the most exacting performance requirements of the UK Water Regulations Advisory Scheme (WRAS). MegaFit products also conform to the American Water Works Association specification AWWA/ANSI C.219 for bolted couplings.

Corrosion and site protection

All MegaFit components, including nuts and bolts, are factory coated with the thermoplastic polymer Rilsan Nylon 11. Rilsan Nylon 11 has met the stringent performance standards of WIS 4-52-01 (Part 1) which requires the highest adhesion, flexibility, penetration and impact resistance characteristics. As a result, MegaFit products are well equipped to withstand transport, storage, site and corrosion damage, eliminating the need for further protection such as on-site wrapping.

Installation

MegaFit products are delivered pre-assembled and ready for installation, which should be done in accordance with the MegaFit installation instructions. Recommended bolt torque:

Up to and including DN80:

55-65Nm, 40-50lbf.ft.

DN100-DN300: 95-120Nm, 70-90lbf.ft.

N.B. Not suitable for use with PE pipe. Please contact our Marketing Department for further assistance.



Specification

A comprehensive range of couplings to suit the various outside diameters of pipes with nominal bores between DN50 (2") and DN300 (12").

MEGAFIT

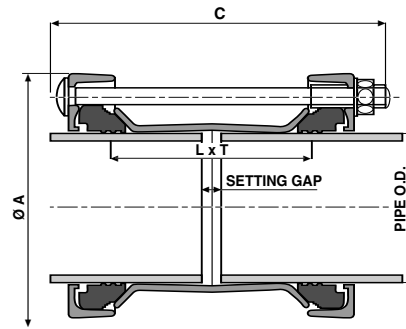

| DN | OD Range | | Bolts No x Dia x Length | A | C | Sleeve Length x Thickness | | Setting Gap | | Weight Kg |
|-----|----------|-------|----------------------------|-----|-----|---------------------------|---|-------------|-----|--------------|
| | Min | Max | | | | L | T | Min | Max | |
| 50 | 43.5 | 63.5 | 4- M12 x 235 | 153 | 243 | 144 | 6 | 18 | 60 | 4.4 |
| 65 | 63.0 | 83.7 | 4- M12 x 235 | 173 | 243 | 144 | 6 | 18 | 60 | 5.4 |
| 80 | 85.7 | 107.0 | 4- M12 x 260 | 194 | 268 | 170 | 6 | 18 | 100 | 6.6 |
| 100 | 107.2 | 133.2 | 4- M16 x 290 | 234 | 296 | 180 | 6 | 18 | 110 | 8.8 |
| 125 | 132.2 | 160.2 | 4- M16 x 290 | 265 | 296 | 180 | 6 | 18 | 110 | 11.1 |
| 150 | 158.2 | 192.2 | 4- M16 x 340 | 305 | 346 | 213 | 6 | 18 | 130 | 14.5 |
| 175 | 192.2 | 226.9 | 4- M16 x 340 | 346 | 346 | 215 | 7 | 18 | 130 | 19.5 |
| 200 | 218.1 | 252.1 | 4- M16 x 340 | 371 | 346 | 220 | 7 | 18 | 135 | 21.7 |
| 250 | 266.2 | 300.2 | 6- M16 x 420 | 419 | 431 | 300 | 7 | 18 | 215 | 30.8 |
| 300 | 315.0 | 349.0 | 6- M16 x 420 | 468 | 431 | 300 | 8 | 18 | 215 | 37.5 |

MEGADAPTOR

Flange adaptors designed to join pipes of various materials and outside diameters to flanges of the same nominal size.*

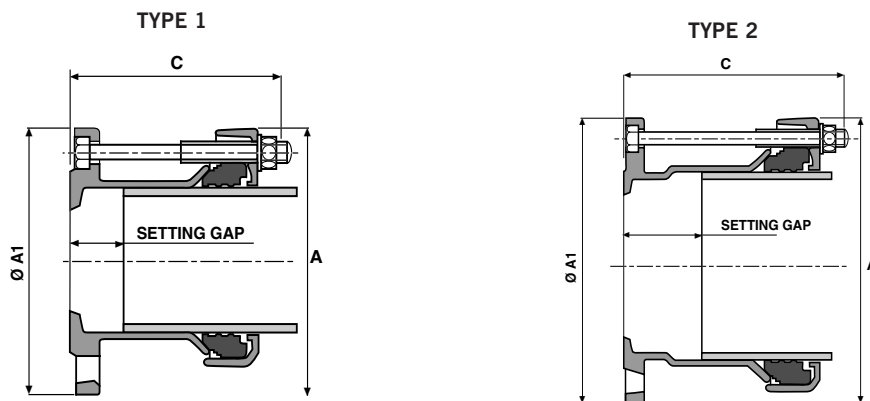

| DN | OD Range | | Flange Nominal | Flange Drilling | Bolts No x Dia x Length | A | A1 | C | Setting | | Type | Weight Kg |
|------|----------|-------|-------------------|--------------------|----------------------------|-----|-----|-----|---------|-----|------|--------------|
| | Min | Max | | | | | | | Min | Max | | |
| 50 | 43.5 | 63.5 | 50 | PN10/PN16 | 4- M12 x 125 | 153 | 165 | 136 | 25 | 35 | 1 | 4.1 |
| 65 | 63.0 | 83.7 | 65 | PN10/PN16 | 4- M12 x 125 | 173 | 185 | 136 | 25 | 35 | 1 | 4.8 |
| 80 | 85.7 | 107.0 | 80 | PN10/PN16 | 4- M12 x 145 | 194 | 200 | 156 | 30 | 60 | 1 | 8.7 |
| 100 | 107.2 | 133.2 | 100 | PN10/PN16 | 4- M16 x 180 | 234 | 220 | 193 | 57 | 85 | 2 | 9.1 |
| 125 | 132.2 | 160.2 | 125 | PN10/PN16 | 4- M16 x 160 | 265 | 248 | 173 | 28 | 65 | 1 | 10.5 |
| 150 | 158.2 | 192.2 | 150 | PN10/PN16 | 4- M16 x 210 | 305 | 307 | 223 | 70 | 100 | 2 | 13.5 |
| 175* | 192.2 | 226.9 | 200 | PN10/PN16 | 4- M16 x 190 | 346 | 340 | 203 | 25 | 80 | 1 | 17.2 |
| 200 | 218.1 | 252.1 | 200 | PN10/PN16 | 4- M16 x 230 | 371 | 370 | 243 | 75 | 130 | 2 | 21.7 |
| 250 | 266.2 | 300.2 | 250 | PN10 or PN16 | 6- M16 x 270 | 419 | 416 | 284 | 80 | 160 | 2 | 28.6 |
| 300 | 315.0 | 349.0 | 300 | PN10 or PN16 | 6- M16 x 270 | 468 | 468 | 284 | 80 | 160 | 2 | 35.8 |

When ordering the nominal sizes 250 and 300mm, please specify flange drilling PN10 or PN16.

*DN175 MegaDaptor supplied with DN200 flange.

Material Specification

All MegaFit products are designed and manufactured under quality management systems certified to BS EN ISO 9001, have been tested to the UK Water Regulations Advisory Scheme and conform to the American Water Works Association's standard AWWA/ANSI C.219 for bolted couplings.

Centre Sleeve/End Rings*

SG ductile iron BS EN 1563:1997, or
rolled steel to BS EN 10025:1993 Grade S 275

Flange Adaptor Body*

SG ductile iron BS EN 1563:1997, or
mild steel to BS EN 10025:1993 Grade S 275

Bolts

to BS EN ISO 898:1999 Property Class Grade 4.8 equivalent
DIN 267 - Part 3:Class 4.8

Nuts

to BS 4190:2001 Grade 4 equivalent
DIN 267 - Part 3:Class 4.6

Washers

BS 1449:Pt2:1983 grade 304 S15

Gasket

EPDM compound Grade 'E' to BS EN 681-1:1996 WRAS
approved, or

nitrile compound Grade 'T' to DIN 3535-3

'E' temperature range: -40°C to +90°C.

Suitable for water, sewage, many strong and oxidising chemicals,
food applications. (Not suitable for fluctuating temperature,
e.g. heating systems.)

'G' temperature range: -20°C to +100°C.

Suitable for natural gas, petroleum products, low aromatic fuels
and compressed air.

Coating

Flange adaptor body, centre sleeve, end rings are
coated in Rilsan Nylon 11 to WIS 4-52-01 (Part 1).

Bolts*, T bolts and nuts are:

Zinc plated to BS 1706:1990 followed by Sheraplex coating to
WIS 4-52-03 for double protection.

* Materials of construction at the discretion of Viking Johnson.

Viking Johnson reserves the right to modify the details in this publication as products and specifications are updated and improved.

Note:

MegaFit couplings do not resist end load - adequate restraint must be provided.

For further information on all Viking Johnson products and services contact our Marketing Department.



ISO 9001



ISO 14001

CRANE

A Crane Co. Company



Viking Johnson

46-48 Wilbury Way

Hitchin

Hertfordshire

SG4 0UD

United Kingdom

Tel: +44 (0)1462 443322

Fax: +44 (0)1462 443311

email: info@vikingjohnson.com

www.vikingjohnson.com